

GRAVELY

A DIVISION OF CLARKE-GRAVELY CORPORATION
To continue its program of quality and design improvement, the manufacturer reserves the right to change specifications, design or prices without notice and without incurring obligation.

OWNERS MANUAL

40" COMMERCIAL MOWER

CONSISTS OF:

11362E1 40" Commercial Drive
11368E1 40" Commercial Deck



40" COMMERCIAL MOWER ATTACHED TO C12 TRACTOR WITH DUAL WHEELS

GENERAL

1. The 40" Commercial Mower is a front mount unit designed and built to give many years of excellent service. The mower is recommended for rough mowing conditions; has all gear drive from engine to mower, heavy-duty steel deck, rugged skids and casters, and 2 adjustable blades. The mower attaches to both 2 and 4 wheel tractors (see paragraph 3).
2. The Owners Manual includes the parts list, setting up the mower, safety, operation, and maintenance instructions. Use the parts list for reference to individual part numbers. If further information is necessary contact the local Gravelly dealer.
3. Height: 15-1/2" Weight: 182 lbs.
Length: 34-3/4" Width: 42"
Cutting Width: 40"
Deck: Reinforced, welded steel.
Drive: Right angle bevel gear, tapered roller bearings, cast iron housing, 2 self-adjusting spring tensioned V-belts.

Blades: 2 steel, hi-strength, hi-lift, 20-1/2" length, 3/16" thick

Features: Adjustable casters, adjustable swivel action.

Purpose: Heavy mowing conditions.

Recommended for the following tractors:

7.6 - C10A - C12

424 - 430 - 432

810 - 812 - 814 - 816S

Required attaching kits:

7.6 - C10A - C12: None

424 - 430 - 432:

15840E1 Front Drive Kit

11601E1 Front Adapter Kit

810 - 812 - 814 - 816S:

19075E1 Front Drive Kit

11601E1 Front Adapter Kit

Recommended optional equipment for special applications:

7.6 - C10A - C12: None

Riding Tractors:

20181E1 Wheel Brake Kit, 800 Series

11924E1 Front Wheel Weights

Recommend option for riding tractors without hydraulics:

11271E1 Lift Assist Kit

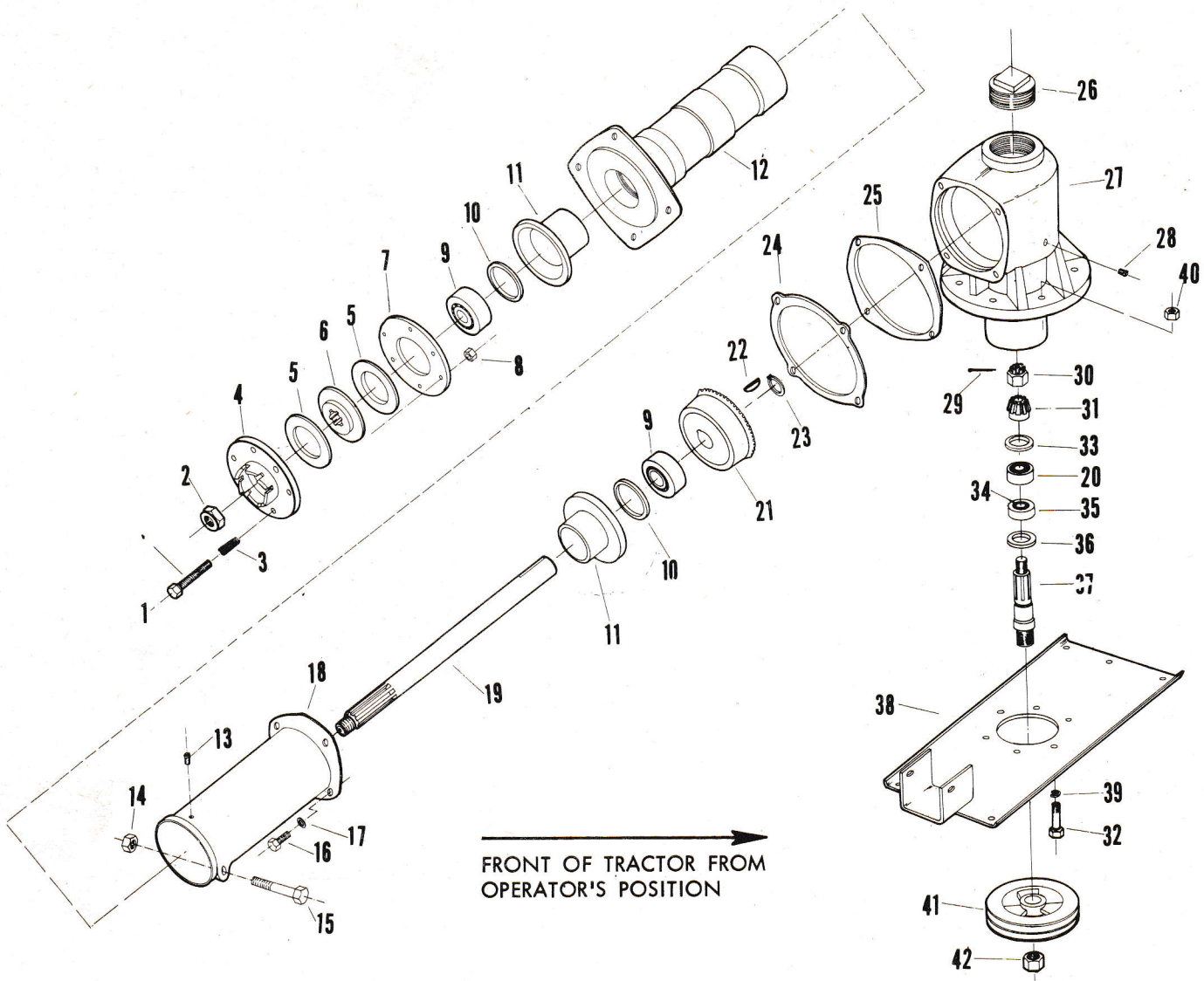

FRONT OF TRACTOR FROM
OPERATOR'S POSITION

ITEM NO.	PART NO.	DESCRIPTION
1	181618	Bolt, Hex 5/16-24 x 1-3/4
2	13412P1	Nut, Lock Esna 5/8-18 Light Thin
3	12871P1	Spring
4	12867P1	Plate, Dog
5	12870P1	Washer, Friction
6	12869P1	Plate, Drive
7	12868P1	Plate, Back
8	18277P1	Nut, Lock Esna 5/16-24 Light Thin
9	13143P1	Bearing, Race
	13144P1	Bearing, Cone
10	13122P1	Seal, Oil
11	12550P1	Retainer, Oil Seal
12	11815P1	Shaft, Housing
13	94110100	Fitting, Lube 1/8
14	435507	Nut, Lock 1/2-13 Washer Insert Hex
15	180193	Bolt, Hex 1/2-13 x 3-3/4
16	180122	Bolt, Hex 3/8-16 x 1
17	138542	Washer, Lock 3/8 Int Tooth
18	12023P1	Casting, Swivel
19	12566P1	Shaft, Drive
20	13145P1	Bearing, Roller Race
	13146P1	Bearing, Roller Cone
21	12862P1	Gear, Bevel
22	120502	Key, Woodruff 3/16 x 7/8 Hard
23	13187P1	Ring, Retaining
24	14101P1	Shim, Gear .020
	12490P1	Shim, Gear House .005
25	12491P1	Gasket
26	10499P1	Plug, Pipe 2 In. W/Filler Plug
27	9236P1	Housing, 42 In. Mower
28	103877	Plug, Pipe 1/8 In. Sq. Hd.
29	119120	Pin, Cotter 3/32 x 1-1/4
30	125384	Nut, Slotted 5/8-18 Hex Thick
31	12850P1	Gear, Bevel
32	9229P1	Bolt, Hex Special
33	12852P1	Shim, Gear
	13646P1	Shim, Gear .010
34	13142P1	Bearing, Roller Cone
35	13139P1	Bearing, Roller Cone
36	13171P1	Seal, Oil (Dual Lip)
37	11363P1	Shaft, Drive Rotor
38	11366A1	Plate, Mounting Weldment
39	120384	Washer, Lock 1/2 Spring
40	120378	Nut, Hex 1/2-13
41	11364P1	Sheave, Drive
42	11365P1	Nut, Special
NS	10102A1	Attachment Clutch Assembly

fig 5 ILLUSTRATED PARTS LIST (Cont.)

ASSEMBLY

1. Unpack the drive and deck.
2. Remove the belt covers, fig 1, Items 27.
3. Mount the idlers on the studs as in fig 2. Note the different sleeve lengths of the idlers. The short sleeve goes next to the high rotor and the tall sleeve goes next to the low rotor. Set the idlers on the studs with the extended sleeves down. Work from the rear of the mower.

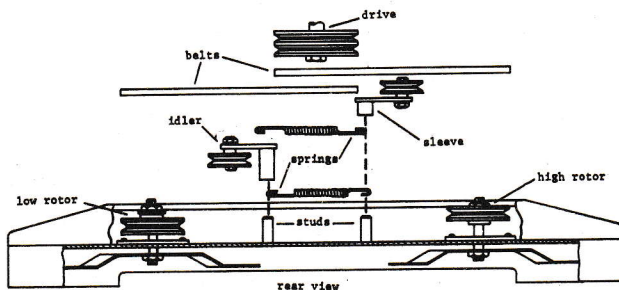

fig 2

4. Set the belts as in fig 3; low belt first. This belt positioning is important for ease of assembly.

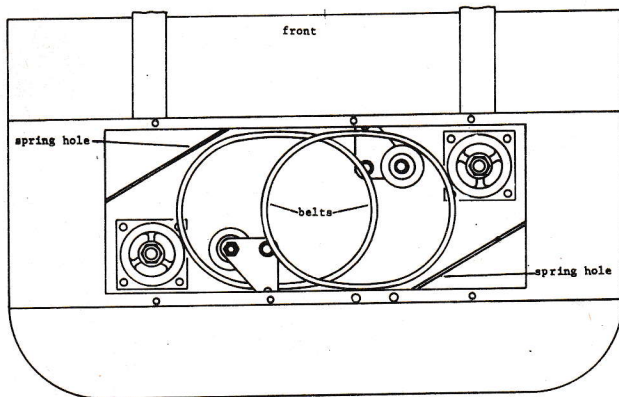

fig 3

5. Hook the springs to the idler assembly from underneath as in figs 2 & 4, solid lines.
6. Set the drive in position on the deck; do not bolt it down. Slip the belts on the drive pulley and then on the rotor pulleys. Let the idlers float at this time; solid lines, fig 4.

7. Bolt the drive to the deck. The 2 carriage bolts are inserted from under the deck, fig 1, Items 41, 42 & 43. Be sure that the heads seat properly in the deck. The 3 hex bolts fasten from the top, fig 1, Items 29 & 40. Start all bolts and nuts before tightening.

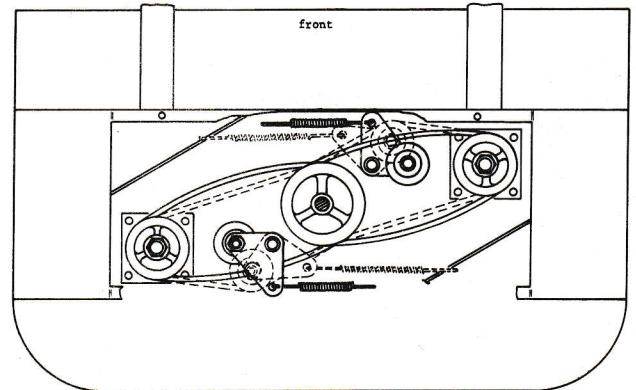

fig 4

8. Working from the sides, grip the springs with a spring puller or clamp-lock pliers or equivalent. Extend the spring hook up, over, and through the spring hole. The belts are now in tensioned running position; dotted lines fig 4.
9. Replace the belt covers.
10. Install the bushings in the caster wheels and bolt the wheels in the caster forks.

LUBRICATION

1. Grease the spindle bearing weldment housing through the grease fitting, with general purpose grease fig 1, Item 8 & 24. Add grease until it comes out the vent hole; opposite side of the grease fitting. Regrease every 8 HOURS of operation or more often when operating in severe dust or sand.
2. Grease the bronze bearing and caster wheels through the grease fittings with general purpose grease fig 1, Items 38 & 49. Add grease until it comes out the bearings. Regrease periodically, especially when operating in severe dust or sand.

3. Remove filler plug and level plug, fig 6. Fill the gear drive housing to the oil level plug with SAE 90 gear lubricant. Replace the plugs. Check the level periodically especially if signs of leakage are present.
4. Grease the swivel casting through the grease fitting on the casting with general purpose grease. Add grease until it comes out under the swivel adjustment fig 6. Regrease every 8 HOURS of operation.

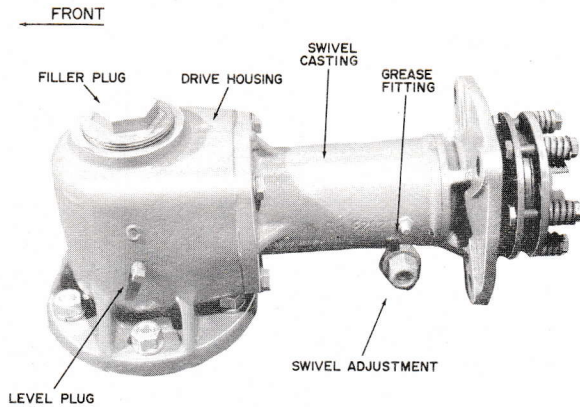

fig 6
DRIVE UNIT

INSTALLATION

1. Before attaching or detaching the mower, STOP the engine, put the PTO control in the "OUT" position.

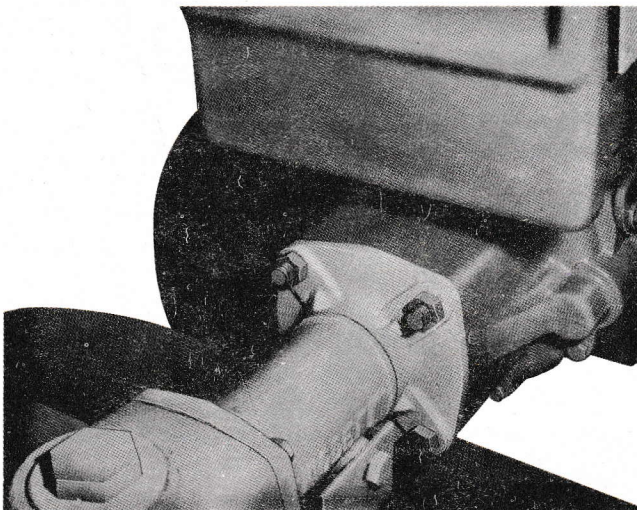

fig 7

2. **7.6, C10A, C12 TRACTORS:**
The mower attaches to the front of the tractors with 2 nuts and 2 bolts. Do not damage the threaded studs, fig 7.
3. **RIDING TRACTORS:**
The mower attaches to the Front Adapter Kit with 2 nuts and 2 bolts. Do not damage the threaded studs, fig 8.

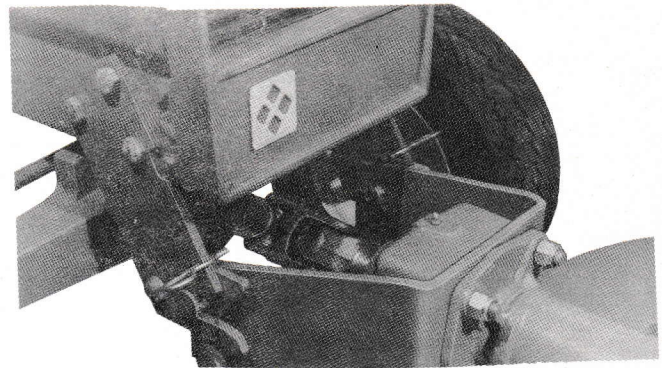

fig 8

SAFETY

1. REFER to the tractor Owners Manual to familiarize yourself with all controls before operation.
2. DO NOT ALLOW PASSENGERS to accompany operator at any time.
3. DO NOT ALLOW CHILDREN to operate equipment, nor allow adults to operate it without proper instruction.
4. INSPECT WORK AREA for rocks, glass, metal, bones, and any other foreign objects. Stay alert for holes and other hidden hazards.
5. USE EXTREME CAUTION when operating on slopes.
6. REDUCE SPEED on all side slopes and sharp turns.
7. DO NOT OPERATE equipment except from proper operator's position.
8. KEEP SAFETY devices and shields in place at all times.

9. DISENGAGE POWER to attachment and stop engine prior to making any adjustment or clearing the unit.
10. DO NOT WEAR LOOSE fitting clothing.
11. KEEP HANDS, feet, hair, clothing, etc., away from moving parts.
12. KEEP BYSTANDERS and pets removed from the work area.
13. EXERCISE CAUTION to avoid slipping or falling, especially when operating in reverse with two wheel tractors.
14. DIRECT DISCHARGE so as not to endanger life or property; such as people, pets, structures, cars, etc.

OPERATION

1. Refer to the tractors Owners Manual for safety and operating instructions to engage and disengage the PTO (power take-off).
2. Operate the engine at full speed. In thick, lush growth reduce ground speed (not engine speed) to allow the mower enough time to cut and discharge.

ROUTINE MAINTENANCE

1. Perform the lubrications as described in LUBRICATION, paragraphs 1 through 4.
2. Check each rotor shaft nut to insure tightness fig 1, Item 15. See ADJUSTMENTS, paragraph 6.
3. Check all nuts and bolts to insure tightness.
4. Sharpen and balance the blades.
5. Clear the mower of cuttings and debris.

REMOVAL FROM TRACTOR

1. Reverse the procedure for attaching; see INSTALLATION, paragraphs 1 through 3.

ADJUSTMENTS

1. **SWIVEL ACTION:** The swivel action is regulated by the nut and bolt on the swivel casting, fig 5. Loosening allows more action, tightening reduces the action. The swivel action should allow the mower to follow ground contour.
2. **CASTERS:** The caster wheels should be adjusted (if necessary) after the mower is attached to a tractor. Raise or lower the casters, by use of the spacers, to make the mower level with the ground, fig 6, Item 46.

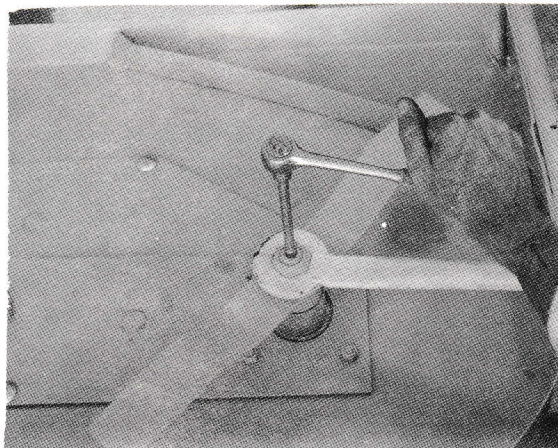

fig 9

3. **BLADE REMOVAL:** STOP the engine, Put the PTO in the OUT position. Put the operating levers in NEUTRAL. BE SURE the blades have stopped. Remove the mower from the tractor. Turn the mower upside down. Hold the rotor shaft with a 3/8" socket drive and remove the nut with a 15367E1 Gravely Wrench or equivalent, fig 9. Do not use the top spindle nut to hold the spindle from turning.
4. **BLADE SHARPENING:** Sharpen the blades. Balance after sharpening.
5. **CUTTING HEIGHT:** Place the collars above and/or below the blade for adjustment, fig 1, Items 19, 20, 21. Note that the collars are not the same thickness. Keep the same combination on both rotors.

6. **BLADE INSTALLATION:** Place the blade and collars on the shaft at the desired cutting height. Put the flat washer and nut on as in
7. **BELT REMOVAL:** Remove the belt covers. Unhook one end of each spring; use a spring puller or clamp-lock pliers. Remove the drive. Remove the belts. See figs 2, 3, & 4. fig 1, Item 14 and 15. Hold the rotor shaft with a 3/8" socket drive and torque the nut to 100 ft. lbs. Similar tightness can be reached with a Gravelly 11367E1 Wrench or any 16" length handle wrench when used by an average man, fig 9.
8. **BELT INSTALLATION:** See **ASSEMBLY** paragraphs 4, 6, 7, 8, and 9.
9. Safety clutch action is regulated by the attachment clutch assembly, fig 5, Items 1, 3, 4, 5, 6, 7 and 8. Loosen all 6 nuts, Items 8. Tighten the 6 bolts all the way into the threaded back plate, Items 1 & 7. Back off each bolt 1/2 turn. Lock the bolts in position with the nuts.

STORAGE

1. Perform all that applies from **ROUTINE MAINTENANCE** and **LUBRICATION**.
2. Apply a light coat of oil to preserve finish and appearance.

WARRANTY

Products manufactured by Gravelly are warranted to be free from defective material and workmanship for a period of one year from date of purchase, under normal use by a homeowner, and for a period of ninety (90) days from date of purchase, when used for commercial purposes.

Any defective part manufactured by Gravelly will be replaced without charge provided such part is certified as defective by the manufacturer or by the manufacturer's expressly authorized representative.

IMPORTANT PROVISIONS

The foregoing warranty is in lieu of all others and GRAVELLY MAKES NO REPRESENTATION OR WARRANTY OF ANY KIND, EXPRESS OR IMPLIED, AS TO MERCHANTABILITY, FITNESS FOR PARTICULAR PURPOSE, OR ANY OTHER MATTER.

This warranty is not subject to change or modification by field representatives or Gravelly dealers.

Certain components carry separate warranties by the manufacturer of such components. Defective components are subject to their manufacturer's warranties, and any claims, work, or return of parts must be through an authorized Gravelly dealer. Service costs for the transporting of a unit to and from the dealer are the responsibilities of the customer, and when such service is performed by the dealer, the dealer will charge the customer the usual rate for such service.

It is the customer's responsibility to mail the "Warranty Card" to the manufacturer within fourteen (14) days after date of purchase to ensure prompt handling of any warranty claim by the dealer or the manufacturer.



A Division of Clarke-Gravelly Corporation
ONE GRAVELLY LANE
Clemmons, North Carolina 27012